



## HYSYS SIMULATION OF N<sub>2</sub> EXTRACTION PROCESS

Dr/ Sameh Tawfik Abd Elfattah Mahmoud

*Assistant Professor, Mechatronics Engineering Department, Alexandria Higher Institute for Engineering and Technology (AIET)*

*Email: [sameh.tawfik@aiet.edu.eg](mailto:sameh.tawfik@aiet.edu.eg), Mob: +20-100-1808-616*

**Abstract:** *Various components of air have been separated for different purposes for their easy availability in the atmosphere. Among those components Nitrogen separation process is very important in chemical engineering sector since it has wide usage in different processes. There are various technologies that are used for the separation of nitrogen. Among those most common is via LINDE-HAMPSON cycle. This paper presents analysis of thermodynamic cycle commonly used for liquefaction of Nitrogen (N<sub>2</sub>) under given set of operating condition and efficiencies. The liquefying temperature of Nitrogen being -200 °C is taken into consideration. This paper also presents the simulation of this process HYSYS for the separation of N<sub>2</sub> from air. Simulation result gives the value of product nitrogen purity of 91.75%.*

**Keywords:** *Cryogenic, HYSYS Simulation, Liquefaction, Nitrogen.*

### Introduction

Earth is surrounded by air [1] and nitrogen is one of the main components of air. Nitrogen is a very common product and used in different types of chemical industries. Air is the main source of Nitrogen. Nitrogen can be separated from air by liquefaction of air. Different processes can be used to separate nitrogen from air. Among these cryogenic process is the most used process for air separation.



The word cryogenic means production of icy cold, but today it is synonym for low temperatures. On temperature scale there is no clear distinction where ordinary refrigeration range ends and cryogenic begins. However the National Bureau of Standards at Boulder, Colorado considers temperature below 123K as cryogenic operating temperature. This can be accepted because boiling temperature of permanent gases like helium (He), hydrogen (H), neon (Ne) etc. are below 123K. Cryogenic engineering deals with development and improvement of low temperature techniques, processes and equipment. It deals with utilization of low temperature phenomena. In general cryogenic system refers to interacting group of components involving low temperature. Examples are (Air liquefaction plant, helium refrigerators etc.). The cryogenic separation [2] process requires a very tight integration of heat exchangers [3] and separation columns to obtain a good efficiency and all the energy for refrigeration is provided by the compression of the air at the inlet of the unit. To achieve the low distillation temperatures an air separation unit requires a refrigeration cycle that operates by means of the Joule–Thomson effect, and the cold equipment has to be kept within an insulated enclosure (commonly called a "cold box"). The cooling of the gases [4] requires a large amount of energy to make this refrigeration cycle [5] work and is delivered by an air compressor. Modern air separation units use expansion turbines for cooling; the output of the expander helps drive the air compressor, for improved efficiency. Simple LINDE-HAMPSON cycle, CLAUDE cycle etc. are the main cryogenic [6] processes. LINDE cycle is very simple and operating cost is very low. CLAUDE cycle is mainly used for achieving highly pure product. Computer based simulation has become popular nowadays for different chemical engineering purposes. Our aim is to represent production of N<sub>2</sub> in renowned aspen HYSYS software [7] .

Making some assumptions and using hypothetical units we have performed the  $N_2$  production simulation. Though it does not give the real world performance or the real life production environment, but it can give relief from making wide range of experiment without making the small scale reactors.

## Methodology

The process of separation of nitrogen from atmospheric air is simulated in HYSYS simulation software. It provides quite accurate results comparing to real plant of industries[8] which makes it an efficient simulator. It provides comprehensive thermodynamics basis for accurate determination of physical properties, transport properties, and phase behavior[8]. In this simulation we used (Peng-Robinson) model fits best to equilibrium since components are gases and non-polar. The components that are used in this process are  $O_2$ ,  $N_2$ . These gases are non-polar. Figure .1 shows the block diagram of the process of separation of nitrogen from air.

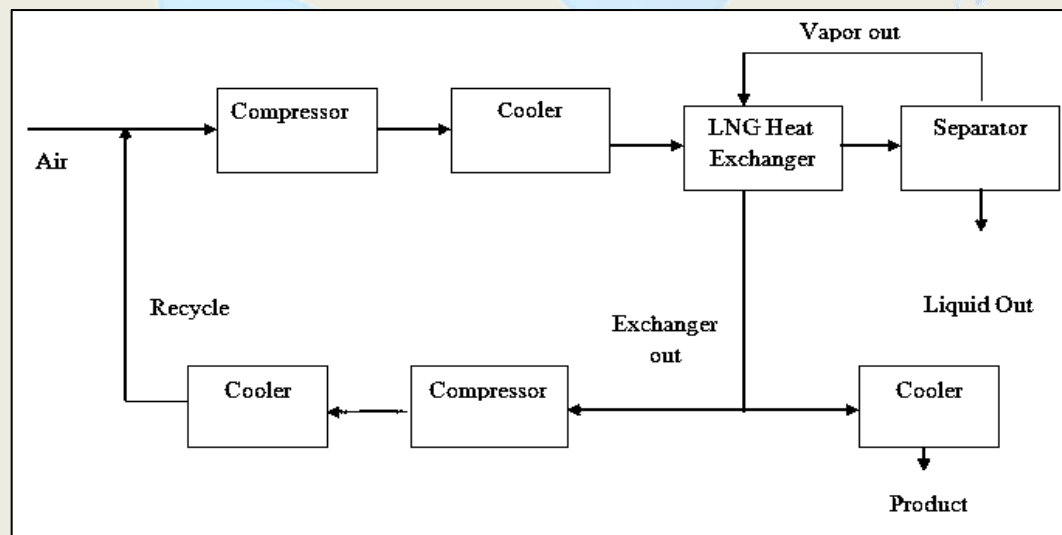
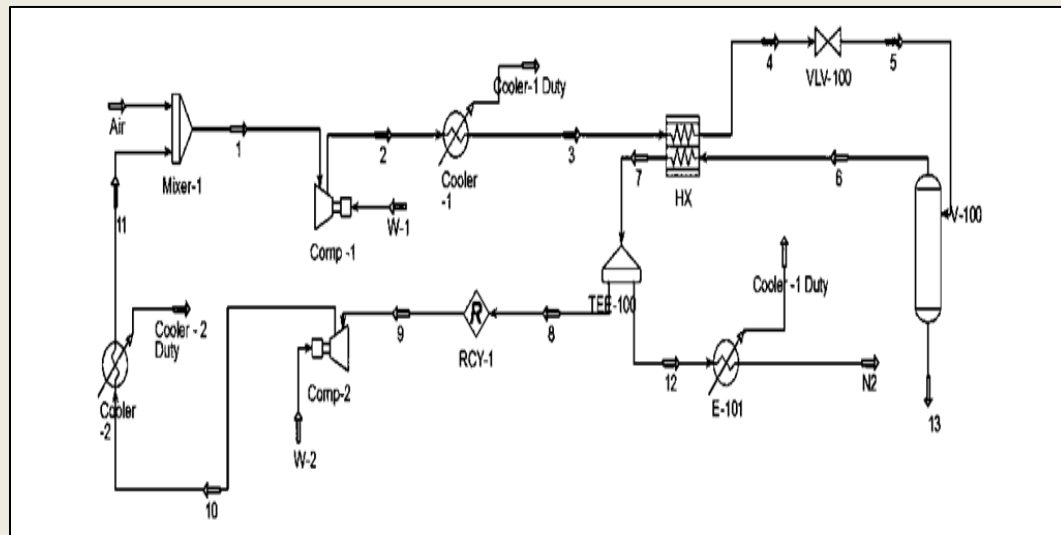

Figure 1: Block diagram of  $N_2$  extraction Process.

Figure .2 shows the HYSYS simulation process flow diagram of the process of separation of nitrogen from atmospheric air.



**Figure 2: HYSYS N<sub>2</sub> Extraction Process flow diagram**

## Methodology

Atmospheric air contains dust. That is why air filtration is needed to remove dust. In our simulation we have considered pure air. The clean, dry air containing mostly nitrogen and oxygen is fed to a mixer at a rate of 1kg/hr where it mixes with the recycle stream at the same intermediate and equilibrium state. The temperature and pressure of both streams entering the mixer were kept at 26.85<sup>0</sup>C and 1bar. The mixed gas stream is then fed to a compressor where the gas is compressed to 250 bar. The temperature of the gas stream coming out from the compressor rises to a very level as the pressure increases. So, a cooler is used to cool the gas stream to room temperature that is that is 26.85<sup>0</sup>C. The gas stream coming out from the first cooler is used as the hot stream inlet of



Liquefied natural gas (LNG) heat exchanger which is actually a counter current shell and tube heat exchanger where the hot fluid flows through the tube side and the cold fluid through the shell side.

The stream coming out from the cooler is used as the hot fluid inlet in our process. A pressure drop of 1 bar in hot stream and 0.2 bars in the cold stream occur. Then an isentropic Joule-Thomson (J-T) valve is used which works at a constant enthalpy and is such that with decrease in pressure a significant drop in temperature is brought about. For the purpose of flashing the vapor-liquid mixture that comes out of the J-T valve, a phase separator is used. The liquid product from the separator is withdrawn. Meanwhile the vapor product is fed to the LNG heat exchanger as the cold fluid inlet. The outlet stream from the LNG heat exchanger is passed through a tee and the stream is split into two different streams. One of the two streams is used as the recycle stream in the mixer while the other one is our product stream. We have to recycle almost 96% of the stream coming out from heat exchanger to achieve maximum purity of nitrogen.

## Results and Discussions

After performing the simulation we have found that the product liquid contains almost nitrogen. Final composition of nitrogen has obtained is 91.75%. But this value is expected to be around 99%. Unavailability of process condition is the main reason for getting less percentage of nitrogen products from air. Efficiency of cryogenic systems is much less. That is why the work input per unit mass of gas liquefied is still very high. From the simulation result we have observed the effect of several parameters on production. Those effects are described in below.

### Effect of percentage recycled on composition of N<sub>2</sub> on product stream:

From figure.3, we see that with the increase of percentage recycled of product stream composition of N<sub>2</sub> increases in product stream. At 50% recycling, composition of N<sub>2</sub> becomes almost 82%.

With further increase in recycling percentage, composition increases slowly.

After 75% recycling this rate on increase is greater than before. Hence there is a positive effect of recycling percentage on composition of N<sub>2</sub> in product stream.

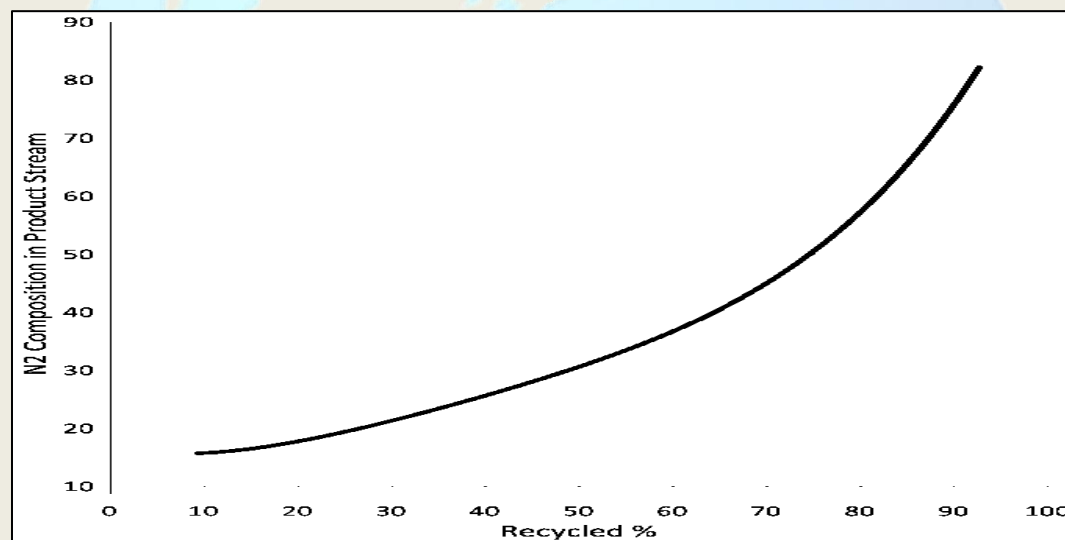

Figure 3: Relation between N<sub>2</sub> % in both recycled and final streams.

### Effect of hot stream temperature on overall heat transfer Coefficient (UA) of LNG heat exchanger

From figure.4, it is clearly seen that with the increase of hot stream temperature of LNG heat exchanger overall heat transfer Cooficint (UA) of LNG heat exchanger increase linearly. At almost 50 °C, UA becomes 40 W/m<sup>2</sup> °C. With the increasing of temperature, UA becomes 60 W/m<sup>2</sup> °C at almost 39 °C.



Then there is significant change in UA with the increase of hot stream temperature of LNG heat exchanger.

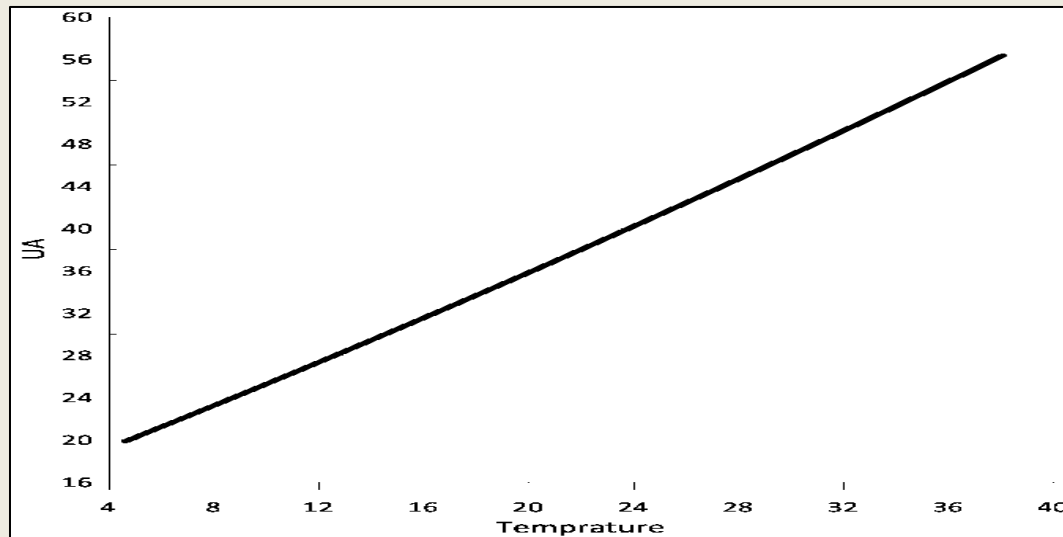
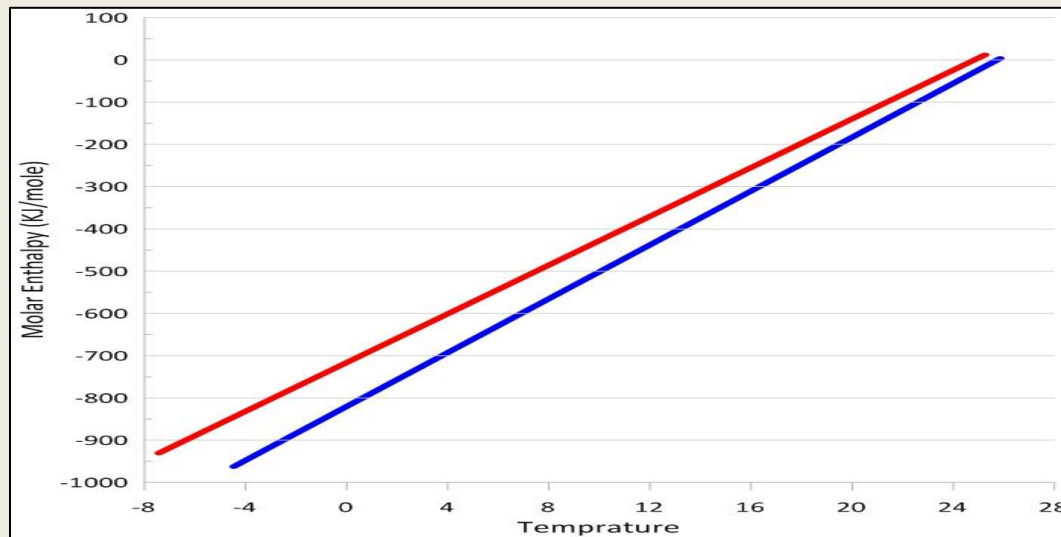

Figure 4: Heat Exchanger characteristic curve

### Effect of temperature of LNG heat exchanger on Molar Enthalpy .

From the following figure we can observe two curves both for the stream of LNG heat exchanger. One is for chilled gas and another for exchanger out. Chilled gas curve shows a straight line pattern. With decrease in temperature of the chilled gas its enthalpy also decreases. At 40 °C chilled gas temperature, molar enthalpy becomes almost - 680 KJ/mole. With further decrease in temperature it becomes -1600 KJ/mole at 15 °C. Exchanger out stream also shows the similar straight line pattern like chilled gas. But in this case, temperature increases. Starting from - 920 KJ/mole at - 5 °C, it increases up to 25 °C with increase in enthalpy.

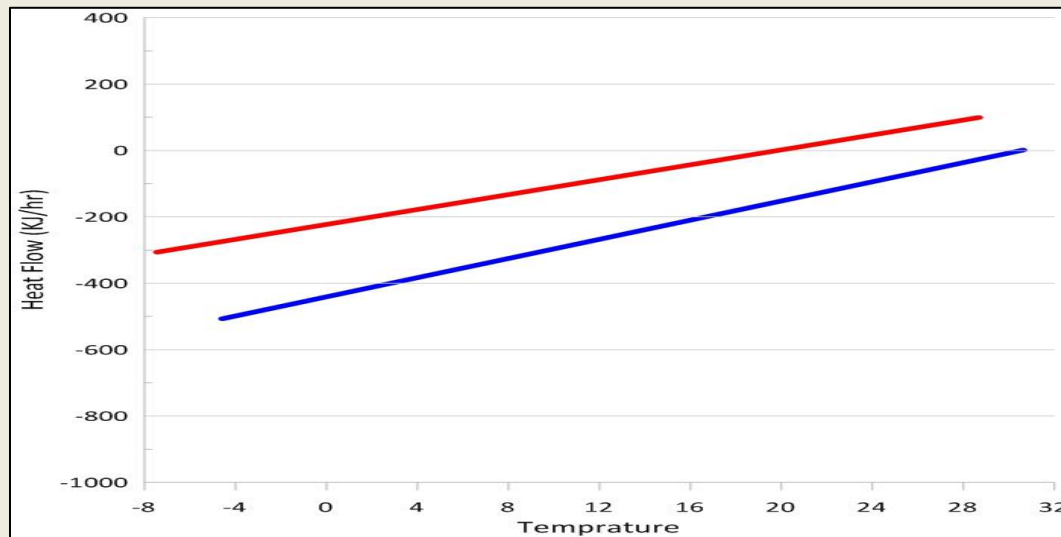

**Figure 5: Heat exchanger Temperature –Enthalpy diagram**

### Effect of temperature of LNG heat exchanger on heat flow.

From the following figure we also can observe two curves both for the stream of LNG heat exchanger. One is for chilled gas and another for exchanger out. Chilled gas curve shows a straight line pattern. With decrease in temperature of the chilled gas its heat flow also decreases. At 40 °C chilled gas temperature, heat flow becomes almost -250 KJ/hr. With further decrease in temperature it becomes -600 KJ/hr at 15 °C. Exchanger out stream also shows the similar straight line pattern like chilled gas. But in this case, temperature increases. Starting from - 330 KJ/hr almost at -8 °C, it increases up to 25 °C with increase in heat flow.





**Figure 6: Heat exchanger Temperature –Heat flow diagram**

There are several factors that can be focused regarding the highest production of nitrogen. Such as:

- In this process we have recycled 96% product to achieve maximum purity and we get 91.75% pure N<sub>2</sub>. This problem can be solved by adding more LNG exchanger or using CLAUDE process. In that case we can get 99% pure N<sub>2</sub> but operating cost will be lot higher.
- Duty of first cooler is very high and it will be very expensive in practical life. We can use more than one cooler in practical life to solve this problem.

In our process we only considered two main components of air. But there exist some other component such as Ar, He, H<sub>2</sub>, CO and CO<sub>2</sub> etc. In practical life we have to consider all the components to separate for getting pure component.

## CONCLUSIONS

Demand of oxygen, nitrogen is increasing day by day. To meet this demand many industries are established to separate these components from common source like atmospheric air.



Among these components the necessity of nitrogen cannot be described in words because it's wide usage almost in all chemical industries and in other sectors where inert environment is mostly needed. Simple LINDE-HAMPSON process is the most basic process of nitrogen separation. A huge scope lies in the improvement of efficiency of cryogenic cycles. User friendly Aspen HYSYS can be used for the optimization and simulation of these cycles. The main problem with these cycles is energy exchange with the surroundings (ambient condition). But advancement has been made in the field of design of heat insulators.

### **Acknowledgments**

I feel always indebted to Allah, the most merciful and I ask him to make this paper useful for all who read it. I would like to express my extreme gratitude to all those who contributed to the achievement of this paper especially both of Prof. Dr. Mostafa Nasr, Dr. Wageeh Elaskary, Dr. Hasnaa Elarwash for their knowledge and motivation.

### **References**

- [1] G. Engl, A. Kröner, T. Kronseder, and O. von Stryk, "Numerical simulation and optimal control of air separation plants," in *High Performance Scientific and Engineering Computing*: Springer, 1999, pp. 221-231.
- [2] K. Maqsood, A. Ali, A. B. Shariff, S. J. C. E. R. Ganguly, and Design, "Process intensification using mixed sequential and integrated hybrid cryogenic distillation network for purification of high CO<sub>2</sub> natural gas," vol. 117, pp. 414-438, 2017.
- [3] W. F. Stoecker, *Design of thermal systems* (no. BOOK). McGraw Hill Book Company, 1980.
- [4] R. F. Barron and G. F. Nellis, *Cryogenic heat transfer*. CRC press, 2017.
- [5] S. M. Dash, "Study of Cryogenic Cycles with Aspen-Hysys Simulations," 2009.
- [6] C. s. Randall F. Barron, 2nd edition.
- [7] P. S. Roy and M. R. J. J. o. C. E. Amin, "Aspen-HYSYS simulation of natural gas processing plant," vol. 26, pp. 62-65, 2011.
- [8] N. Chemmangattuvalappil and S. J. C. E. P. S. Chong, "Basics of Process Simulation With Aspen HYSYS," p. 233, 2017